

TOP OFFSET PIVOT

Description: Both the door and frame portion of the pivot assembly are of cast aluminum. Press fitted into the frame portion is a heavy wall oilite bronze self-lubricating bearing. A stainless steel pivot pin in the door portion completes the assembly.

Application: The frame portion is mortised into the header/transom bar and is attached with screws threaded into the pivot block. The pivot attachment location takes advantage of the strength at the frame joint. The door portion has two bosses which interlock in the door extrusion, to prevent rotation. It is secured in place with two screws through a reinforcing plate which spreads the load. The spring loaded pivot pin allows easy "one man" installation.

Finish: Standard finish is a thermosetting polyester powder coated finish applied to match anodized finishes of #17 Clear, #40 Bronze and #29 Black. Other finishes available upon request. Contact the factory.

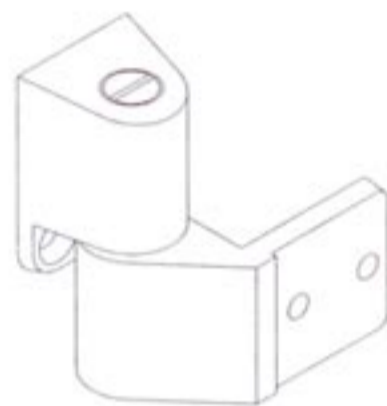

PATENT NO. 4,937,916

STANDARD INTERMEDIATE PIVOT

Description: This aluminum die cast pivot is adjustable and load bearing with the extra benefit of being non handed. The door portion is surface applied with two screws and intragral interlocking boss which resist both rotational and thrust loads. The frame portion is mortised into the frame with just two screws for attachment. The pivot pin is stainless steel which works within a heavy wall, self lubricated oilite bearing. It is also available in electric transfer model.

Application: This pivot is used in conjunction with top and bottom offset pivots for additional strength and door/frame alignment. Use of this pivot is advised on doors experiencing high traffic volume or on doors exceeding 7'-6" (2286) in height. **(not for top pivot replacement)**

Finish: Standard finish is a thermosetting polyester powder coated finish applied to match anodized finishes of #17 Clear, #40 Bronze and #29 Black. Other finishes available upon request. Contact the factory.

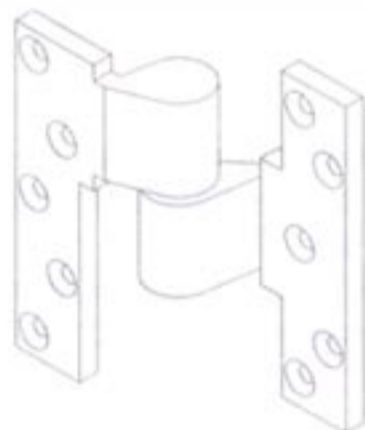

OPTIONAL INTERMEDIATE OFFSET PIVOT

Description: This aluminum pivot is fully mortised into the door and frame and has a 3/4 inch (19.1) offset from the door face. The thrust bearing is corrosion resistant and self lubricating. The pivot pin is hardened Parco-lubricated steel.

Application: This pivot is used in conjunction with top and bottom offset pivots for additional strength and door/frame alignment. Use of this pivot is advised on doors experiencing high traffic volume or on doors exceeding 7'-6" (2286) in height.

Finish: A baked epoxy finish is applied to match anodized finishes of #17 Clear and #40 Bronze.

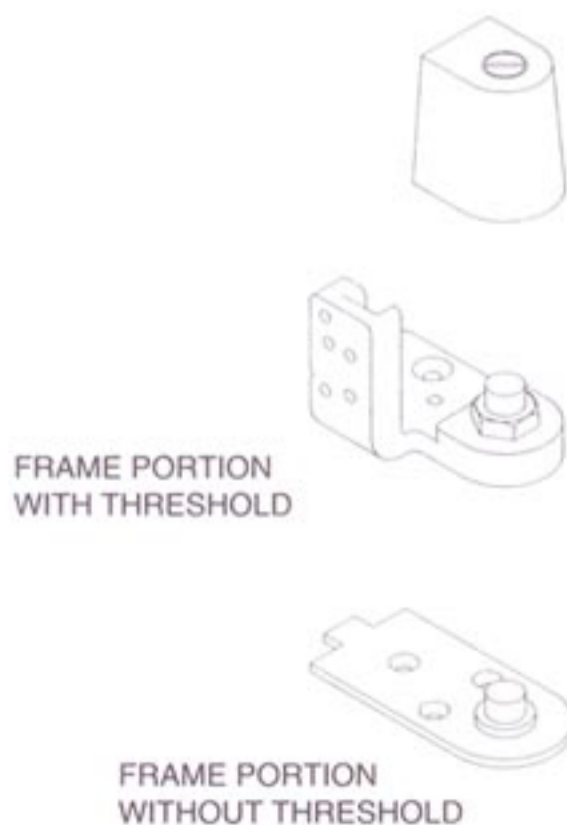

BOTTOM OFFSET PIVOT

Description: Door Portion - is of cast aluminum. Attachment is obtained by back bolting through a plated steel reinforcing plate, the door stile extrusion and threading into the pivot block. A ball-bearing raceway accepts the pivot pin. The door portion provides vertical screw adjustment to achieve proper door, frame, and threshold clearance.

Frame Portion -(with threshold) the pivot base is of cast aluminum with a steel pivot pin. This pivot portion becomes an integral part of the door frame and securely anchors the frame and threshold to the floor.

Floor Portion - (without threshold) the pivot plate is stainless steel with a riveted stainless pivot pin. The plate is fastened at three points directly to the floor.

Application: The bottom offset pivot is used in conjunction with the top, and optional intermediate offset pivot. The frame portion is used with threshold. On interior or vestibule door not requiring threshold the floor mounted portion is used. The door portion provides vertical adjustment with both pivot pieces.

Finish: Standard finish is a thermosetting polyester powder coated finish applied to match anodized finishes of #17 Clear, #40 Bronze and #29 Black. Other finishes available upon request. Contact the factory. The floor portion is a clear finish to match the threshold or stainless steel door without threshold.

HARDWARE

PIVOTS/HINGES

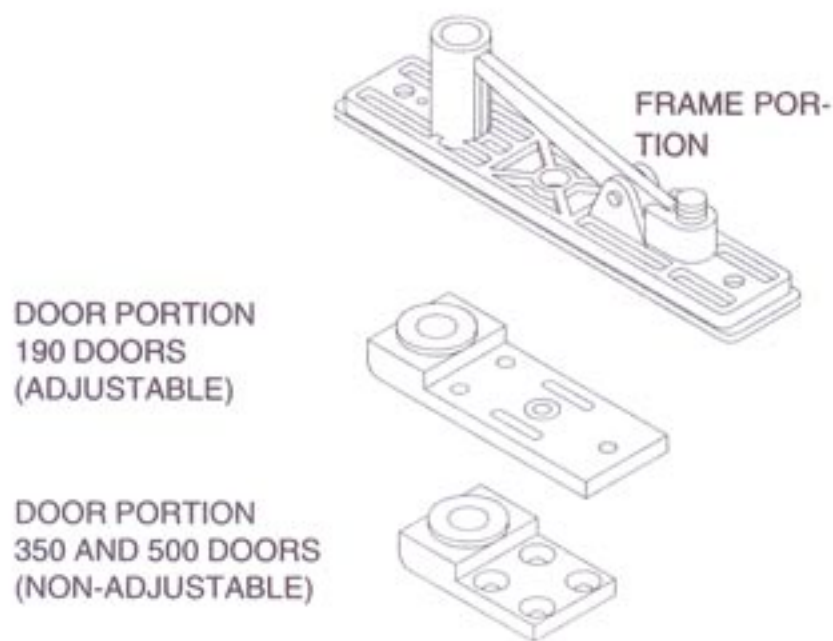

TOP CENTER PIVOT

Description: (Frame Portion)- The "walking beam" frame pivot portion is cast aluminum with a hardened steel pivot pin. The pin is adjustable for additional extension through the transom bar/header. Both door pivot portions are machined aluminum with oilite bronze self-lubricating bearings. All top center hung pivot parts are concealed.

Application: This pivot assembly is used in conjunction with center hung doors with floor closers. The adjustable portion for the 190 Narrow Stile Door provides for a one time only adjustment. Dimension 3" (76.2) long, 1-7/16" (36.5) wide, and 1/2" (12.7) at its thickest point. The 350 Medium Stile and 500 Wide Stile door pivot portion is non-adjustable. Dimensions 2-3/8" (60.3) long, 1-7/16" (35.5) wide and 1/2" (12.7) at its thickest point.

Finish: The frame portion is natural cast aluminum with dress plate to match color of frame. The machined door portion is mill finish.

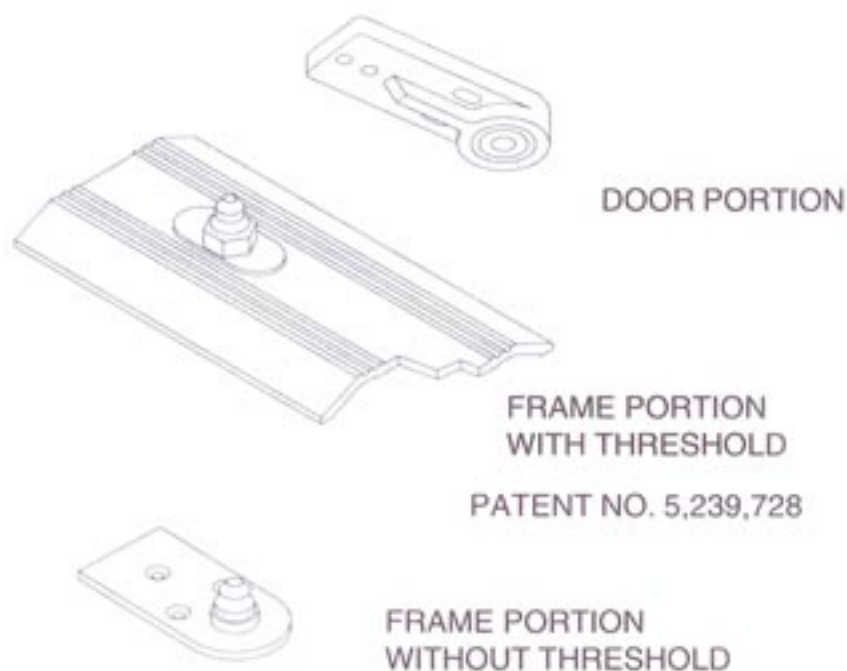

BOTTOM CENTER PIVOT

Description: The low profile center pivot for use with a threshold has an adjustable stainless steel pivot pin that is mounted and locked into the threshold. The center pivot for use without a threshold has a stainless steel pivot pin press fit into a stainless steel plate. The door portion is comprised of a roller bearing press fit into a cast aluminum pivot block.

Application: Both pivot portions, with or without threshold, are used on doors with concealed overhead closer control. On entrances with thresholds the pivot is anchored securely into the threshold. The frame portion is adjustable for proper door and frame clearance. The frame portion for use on doors without threshold is fastened directly to the floor. When no threshold is used, height adjustment is obtained by shimming the pivot block. The door pivot block is securely mounted to the bottom rail web.

Finish: Mill finish is standard for all bottom center pivot parts.

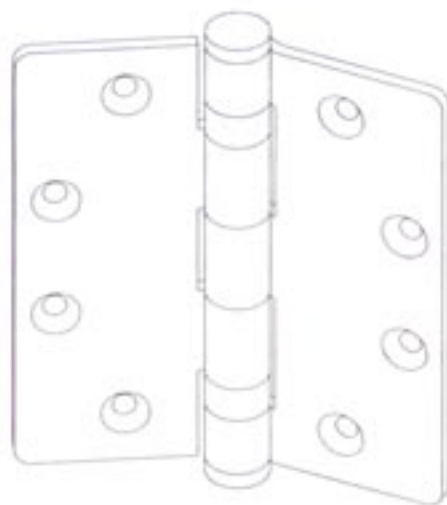

BUTT HINGE

Description: Commercial quality steel or brass hinge with leafs of five knuckle-two ball bearing construction. The hinge barrel is enclosed with button tips and incorporates a non-rising removable pin. Butt hinges with optional non-removable pin are available. The hinge is a radius corner, standard template butt of 4-1/2" x 4" (114.3 x 101.6). The hinge leaf thickness is .134 inches (3.4). It is also available in electric transfer model.

Application: The butt hinge is fully mortised into the door hinge stile and frame hinge jamb. Reinforcing plates are used in both the frame jamb and hinge stile for secure screw anchorage. Butt hinges for corrosive coastal environments also available. The use of an intermediate butt (1-1/2 pair per leaf) is suggested for doors in high traffic areas or for doors over 7'-6" (2286).

Finish: On clear anodized doors the hinge finish is U.S. 26D dull chrome. On Permanodic bronze or black doors the hinge has a dark oxidized finish.

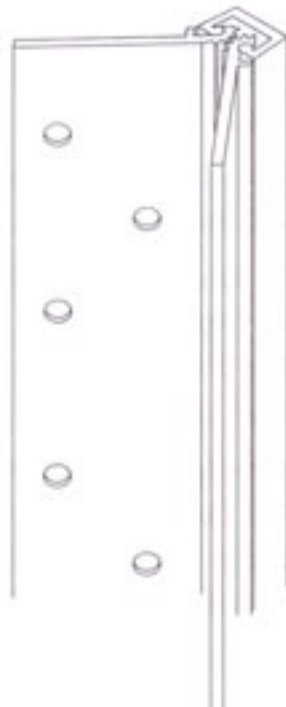

CONTINUOUS HINGE

Description: Quality continuous "geared" hinge incorporating lubricated bearings between the knuckles.

Application: The continuous hinge is surface applied to both the door stile and door frame. Screws are staggered and are approximately 6" (152.4) on center. Continuous hinges are suitable for all entrance configurations.

Finish: Available in #14 Clear, #29 Black and #40 Bronze anodized finishes. Painted finishes are available on a custom basis.